



vortex flow meter

Product introduction

Product Introduction

Product Overview

The vortex flowmeter is a volumetric flowmeter developed based on the Karman vortex principle, designed to measure the volumetric flow rate, standard volumetric flow rate, or mass flow rate of gases, steam, or liquids. It is widely used in industries such as heating, gas supply, chemical processing, environmental protection, metallurgy, textiles, steel, pharmaceuticals, papermaking, and wastewater treatment for the measurement and control of superheated steam, saturated steam, compressed air, and general gases (e.g., oxygen, nitrogen, hydrogen, natural gas, town gas), as well as liquids (e.g., water, gasoline, alcohol, benzene compounds).

Product Features and Advantages

Flow transmitters offer multiple structural configurations, with broad applicability, stronger signals, and wider measurement ranges.

The high performance digital processing technology is adopted, which has better precision and anti-vibration effect.

Measurable for gases, vapors and liquids, with better adaptability.

No moving parts, requiring no maintenance for long-term use, stable and reliable.

The installation is simple and can be made in a variety of structures, such as flange connection, flange clamp (cast or forged), sanitary clamp connection, and threaded connection.

The VRc and VRd series employ patented isolation technology, enabling customized solutions to tackle specialized application challenges.

Operational Principle

When the medium flows through the vortex generator, alternating vortex signals are generated, a phenomenon known as the Karman vortex phenomenon. The number of generated vortices is directly proportional to the flow rate. Therefore, by measuring the rate of vortex generation, the flow rate in the pipeline can be determined.

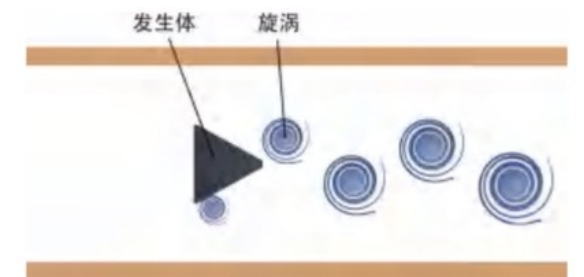

Guide to type selection

Selection Guidance

essential parameter



Vortex Flowmeter-Appearance and Structure

Diameter of flowmeter	DN15-DN600				
Process fluid	Liquid, gas, and steam (single-phase media or media that can be considered as single-phase) with a dryness of >85% can be regarded as single-phase media.				
Process temperature	Low-temperature type: -190~100°C; Normal-temperature type: -45~150°C; Medium-temperature type: -45~250°C; High-temperature type: -45~350°C; Ultra-high-temperature type: -45~400°C; Super-high-temperature type: -45~500°C;				
Pressure rating	1.6-100MPa				
Accuracy	Liquid	±0.5%	±1.0%	1.50%	
	Gas	±0.5%	±1.0%	±1.5%	±2.5%
Range ratio	1:10-1:70				
Reynolds number	1*10 ⁴ ~7*10 ⁶				
Velocity of flow	Liquid flow rate range: 0.3-8 m/s (customizable) Gas and steam flow rate range: 2-70 m/s (customizable)				
Coefficient of drag	Full-pipe type: Cd≤2.4				
Allowable vibration acceleration	0.5-1.0g				
Straight pipe section	Upstream straight pipe section ≥10D, downstream straight pipe section ≥5D				
Pressure loss	Pressure loss P=1.29*p*v ² (Pa), density (kg/m ³), flow rate (m/s)				
Minimum liquid pressure	The minimum vaporization pressure of the liquid, P _{m in} , is calculated as: P _{m in} = 2.7 × P + 1.3 × P _o (Pa).				
Levels of protection	IP65&IP66&IP67				
Explosion-proof sign	Intrinsic Safety / Explosion-Proof / Dust Explosion-Proof				
Ambient condition	Environmental temperature: -35°C to 65°C, relative humidity: 5% to 90%, atmospheric pressure: 86 to 106 kPa Relative humidity: 5%, 90% (no condensation), atmospheric pressure: 86, 106 kPa				
Power Supply Voltage	Non-explosion-proof pulse type: +24VDC; Current type (4-20mA), +24VDC.				
	Intrinsic type	Pulse type: 24VDC, with optional safety barrier Current type (4-20mA): +24VDC, user optional safety gate			
	Explosion-proof	pulse type: +24VDC, current type (4-20mA): +24VDC.			
Power dissipation	<1w				
Output signal	Frequency/Pulse Output: 2-3000Hz, low level 1V, high level 5V; Current output: 4-20mA, Explosion-proof load: 300Ω; Non-explosion-proof load: 500Ω. Control signals, RS485 (Modbus-RTU protocol), Hart protocol, and IoT GPRS, etc.				
Show	Temperature, Pressure, Instantaneous Flow Rate, Cumulative Flow Rate, Flow Unit, Flow Percentage, etc.				
Electrical interface	Internal thread M20*1.5, 1/2NPT				
Transmitter housing	Cast aluminum alloy with polyurethane anti-corrosion coating (other materials subject to agreement)				
Material quality	Standard body materials: Default 304 stainless steel, customizable 316L, titanium alloy, HC, and other special materials Standard sensor specifications: 316L, customizable HC, and other special materials				

Determination of Measurement Range and Aperture

Gas working condition flow range

Inside nominal diameter (DN)	in inches	Gas flow rate range (m/s)	Gas volumetric flow rate (m ³ /h)	Mass e-flow
15	1/2"	5~50	3~30	10~100
20	3/4"	4~60	4~50	13~163
25	1"	4~60	6~100	20~326
32	1 1/4"	3~70	9~180	29~587
40	1 1/2"	3~70	14~280	46~913
50	2"	3~70	20~400	65~1304
65	2 1/2"	3~70	35~700	114~2282
80	3"	3~70	60~1200	180~3912
100	4"	3~70	90~2000	294~6520
125	5"	3~70	120~2400	391~7824
150	6"	3~70	200~5000	652~16300
200	8"	3~70	350~8000	1141~26080
250	10"	3~70	550~11000	1793~35860
300	12"	3~70	800~18000	2608~58680
350	14"	3~70	1100~24000	3586~78240
400	16"	3~70	1400~31000	4564~101060
500	20"	3~70	2300~49000	7500~159740
600	24"	3~70	3400~70000	11084~228200

Note: The mass flow rate is calculated for saturated steam at 160°C, 0.5MPa pressure, and a density of 3.26 kg/m³.

Liquid working condition flow range

Inside nominal diameter (DN)	in inches	Liquid flow rate range (m/s)	Liquid volumetric flow rate (m ³ /h)	Mass flow rate (t/h)
15	1/2"	0.3~7	0.2~6	0.2~6
20	3/4"	0.3~7	0.3~10	0.3~10
25	1"	0.3~7	0.5~15	0.5~15
32	1 1/4"	0.3~7	0.9~25	0.9~25
40	1 1/2"	0.3~7	1.4~40	1.4~40
50	2"	0.3~7	2~60	2~60
65	2 1/2"	0.3~7	3.5~100	3.5~100
80	3"	0.3~7	5~150	5~150
100	4"	0.3~7	10~250	10~250
125	5"	0.3~7	15~350	15~350
150	6"	0.3~7	20~500	20~500
200	8"	0.3~7	35~900	35~900
250	10"	0.3~7	55~1500	55~1500
300	120	0.3~7	80~2000	80~2000
350	14"	0.3~7	100~2700	100~2700
400	16"	0.3~7	140~3500	140~3500
500	20"	0.3~7	220~5500	220~5500
600	24"	0.3~7	310~7900	310~7900

Note: The mass flow rate is calculated based on water's density of 1000 kg/m³.

The lower flow limit may be adjusted for different media and operating pressure conditions, with the specific adjustment range determined by actual operational conditions. Consultation with the supplier's technical team is recommended prior to sales.

selection TABLE

Code	Product line
LUGB	Piezoelectric vortex flowmeter
LUGB-VRc	Isolation and Seismic Turbulent Flowmeter
LUGB-VRd	Innovative Isolated Vortex Flowmeter
Code	Nominal diameter (unit: mm)
010	DN10
015	DN15
020	DN20
02	DN25
03	DN32
04	DN40
05	DN50
06	DN65
08	DN80
10	DN100
12	DN125
15	DN150
20	DN200
25	DN250
30	DN300
35	DN350
40	DN400
45	DN450
50	DN500
60	DN600
Code	Power supply mode
U	24VDC
A	220VAC
v	3.6V lithium battery
Code	Accuracy class
E	0.75
A	1.0
B	1.5
Code	Service environment
P	Conventional type
EX	Explosion proof type
Code	Output method
1	No-output
2	Pulse output-three-wire system
3	4~20mA current output-two-wire system
4	RS485 communication, Modbus protocol (four-wire system)
5	Hart protocol
6	4G
X	Other special customization

selection TABLE

Code	Temperature rating
T0	45° C~150°C
T1	-45°C~250°C
T2	-45° C~350°C
T3	-45° C~400°C
T4	-45° C~500°C
T5	-190°C~60°C
Code	Attended mode
1	Flange type
2	Flange mounting type
3	Simple Insert
4	Inserted ball valve
5	Threaded connection
6	Clamp connection type
X	Other special customization
Code	Medium
2	Liquid
3	Gas
4	Vapour
Code	Compensation method
NO	Uncompensated
P	Temperature compensation
T	Pressure compensation
Code	Pressure rating
H1	1.6MPa
H2	2.5MPa
H4	4.0MPa
H6	6.3MPa
H10	10.0MPa
H16	16.0MPa
H25	25.0MPa
A1	ANSI 150LB
A3	ANSI300LB
A6	ANSI1600LB
A9	ANSI 900LB
A15	ANSI 1500LB
A25	ANSI 2500LB
XXX	Other special customization
Code	Transmitter type
S	Integrated
F	Split type

Vortex street flow meter dimensions

外形尺寸 of Vortex Flowmeter

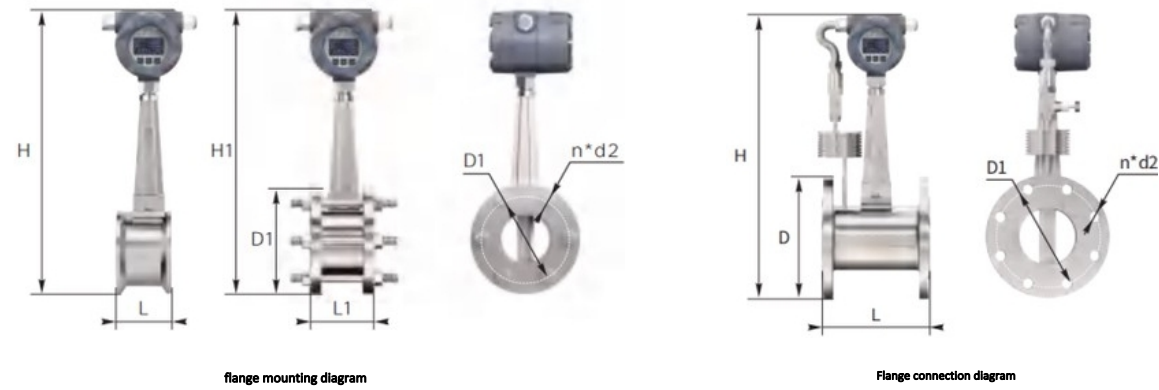

Flange-mounted standard field display dimensions:

Inside nominal diameter	Pressure rating MPa	L mm	L1 mm	D1 mm	H mm	H1 mm	d2 mm	n hole count
DN15	4	64	94	145	380	410	14	3
DN20		64	94	145	380	410	14	3
DN25		64	94	145	380	410	14	3
DN32		64	94	145	380	410	14	4
DN40		75	105	150	390	420	18	4
DN50	1.6	75	105	150	395	420	18	4
DN65		75	105	165	405	435	18	4
DN80		75	105	180	420	450	18	6
DN100		90	120	210	440	475	18	6
DN125		100	136	235	470	505	18	8
DN150		115	151	270	490	530	22	8
DN200		135	171	335	540	590	22	8
DN250		150	192	375	590	635	22	10
DN300	164	206	425	640	685	22	10	

Flange connection standard field display dimensions:

Inside nominal diameter	Pressure level (MPa)	L mm	D mm	H mm	D1 mm	d2 mm	n hole count
DN10	4.0	200	90	387	60	14	4
DN15		200	95	389	65	14	4
DN20		200	105	394	75	14	4
DN25		200	115	399	85	14	4
DN32		200	140	412	100	18	4
DN40		200	150	420	110	18	4
DN50		200	165	432	125	18	4
DN65		200	185	450	145	18	8
DN80	1.6	200	200	465	160	18	8
DN100		200	220	490	180	18	8
DN125		200	250	514	210	18	8
DN150		200	285	543	240	22	8
DN200		200	340	595	295	22	12
DN250		250	405	653	355	26	12
DN300		250	460	710	410	26	12

VRc isolation seismicseries vortex street flow meter exterior dimensions

External Dimensions of Vortex Flowmeter for VRc Isolation and Anti-Seismic Series

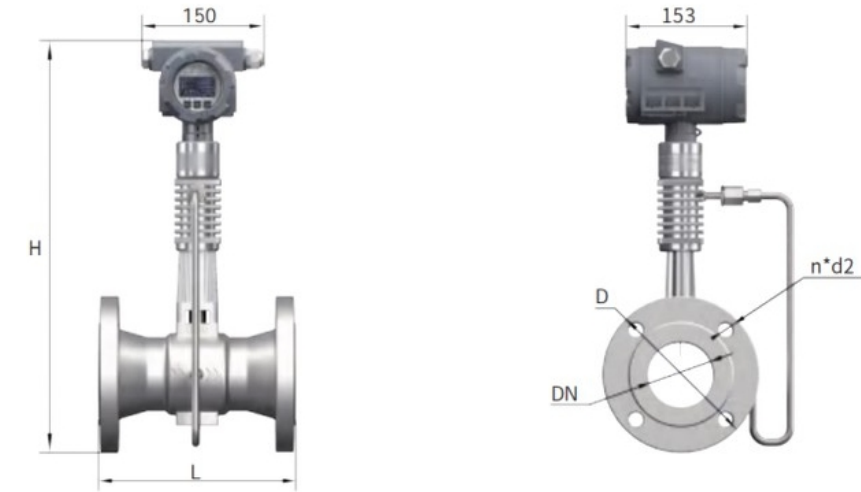

Schematic diagram

of the VRc series vortex street. Dimensions of the VRc series vortex street:

Inside nominal diameter	Pressure level (MPa)	Long rot	Flange outer diameter (mm)	Height H(mm)	Middle heart distance K (mm)	Number of bolt holes n	Bolt hole diameter d2 (mm)
DN15	1.6	180	95	395	65	4	14
DN20		180	105	400	75	4	14
DN25		180	115	405	85	4	14
DN32		200	140	420	100	4	18
DN40		200	150	430	110	4	18
DN50		200	165	440	125	4	18
DN65		200	185	460	145	8	18
DN80		200	200	475	160	8	18
DN100		250	220	495	180	8	18
DN125		250	250	520	210	8	18
DN150		250	285	550	240	8	22
DN200		350	340	605	295	12	22
DN250		450	405	665	355	12	26
DN300		500	460	715	410	16	26
DN350		500	520	775	470	16	26
DN400		600	580	835	525	16	30
DN500	600	715	940	650	20	34	
DN600	600	840	1045	770	20	36	

VRd Innovative Isolated Vortex Street Flow Meter Dimensions

External Dimensions of VRd Innovative Isolated Vortex Flowmeter

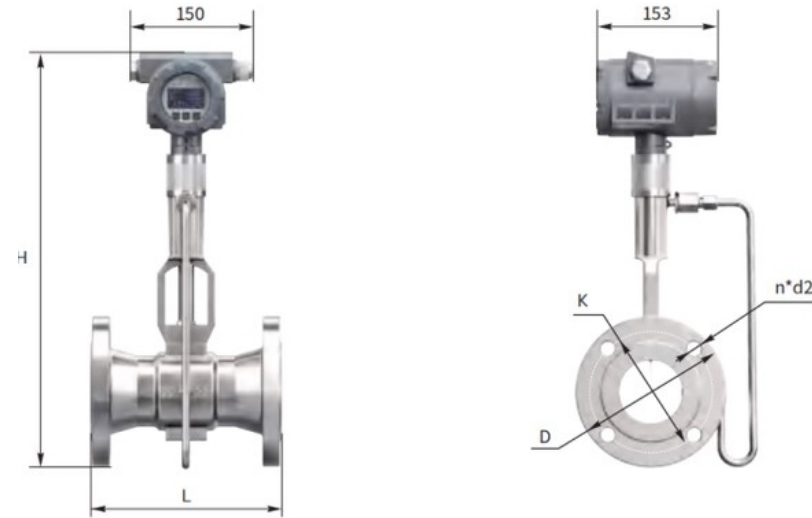

VRd Vortex Series Diagram

VRd series vortex street dimensions:

Inside nominal dia-meter	Pressure rating (MPa)	Length L (mm)	Flange outer diameter (mm)	Altitude H (mm)	Center distance K (mm)	Number of bolt holes n	Bolt hole diameter d2 (mm)
DN15	1.6	180	95	395	65	4	14
DN20		180	105	400	75	4	14
DN25		180	115	405	85	4	14
DN32		200	140	420	100	4	18
DN40		200	150	430	110	4	18
DN50		200	165	440	125	4	18
DN65		200	185	460	145	8	18
DN80		200	200	475	160	8	18
DN100		250	220	495	180	8	18
DN125		250	250	520	210	8	18
DN150		250	285	550	240	8	22
DN200		350	340	605	295	12	22
DN250		450	405	665	355	12	26
DN300		500	460	715	410	16	26
DN350		500	520	775	470	16	26
DN400		600	580	835	525	16	30
DN500		600	715	940	650	20	34
DN600		600	840	1045	770	20	36

Note: If the above dimensions conflict with the actual size, the actual size shall prevail.

Installation requirements

Installation Requirements

Instrument Installation Environment Requirements

1. Flow meters should be installed indoors. If installed outdoors, they must be covered to prevent rainwater intrusion and direct sunlight exposure, which could shorten their lifespan. When wiring the flow meter, the shielding wire should be U-shaped, and the wiring should enter the meter housing from the bottom upward to prevent rainwater from entering the interior.
2. The flowmeter must be protected from strong external magnetic fields, high-voltage electrical equipment, and high-frequency devices, and should not share power supply with these devices.
3. Avoid sharing power supply with devices that pollute the power source, such as frequency converters and welding machines. Install a power purification system when necessary.
4. Avoid high temperatures, extreme cold, corrosive environments, or highly humid conditions. If installation is unavoidable, ensure proper protection for the flow meter.
5. Flow meters should be avoided from installation on pipelines with strong vibrations. If installation is unavoidable, pipe fasteners must be installed at both upstream and downstream 2D positions, along with vibration isolation pads.

Enhance the anti-vibration effect:

6. A sufficient space should be left around the instrument installation point for wiring and regular maintenance.

Requirements for Instrument Piping Installation

Vortex flow meters require specific straight pipe sections upstream and downstream of the installation point. Failure to meet these requirements may disrupt the flow field in the pipeline, compromising the meter's measurement accuracy. Refer to the figure for the required lengths of straight pipe sections upstream and downstream. DN denotes the nominal diameter of the meter, measured in millimeters.

